

**Art.: 3121**  
**Válvula de retención REGE**  
**REGE Check valve**

### Características

1. Válvula de retención monobloque (sólo hasta 2") y desmontable.
2. Construcción en latón forjado s/ UNE-EN 12165.
3. Extremos rosca gas (BSP) hembra s/ ISO 228/1.
4. Temperatura de funcionamiento:  
 Aire: -20° C a 100° C.  
 Gas: -20° C a 60° C.  
 Agua: 0° C a 90° C.
5. Presión máxima de trabajo 25/18/12 bar (PN-25/ PN-18/ PN-12) (Ver tabla).
6. Apta para todo tipo de instalaciones industriales, neumáticas e hidráulicas.
7. Montaje multiposicional (horizontal, vertical y oblicuo).
8. Junta de clapeta vulcanizada de NBR.
9. Muelle en acero inox. AISI 304.

### Features

1. Removable and monobloque (only up to 2") check valve.
2. Hot-forging brass according to UNE-EN 12165.
3. Threaded female ends gas (BSP) acc/ ISO 228/1.
4. Working temperature:  
 Air: -20 °C to 100° C.  
 Gas: -20 °C to 60° C.  
 Water: 0 °C to 90° C.
5. Maximum working pressure 25/18/12 bar (PN-25/ PN-18/ PN-12) (See table).
6. Suitable for all kind of industrial, pneumatic and hydraulic installations.
7. Multipositional setting up (horizontal, vertical and oblique).
8. Vulcanized NBR gasket plate.
9. Stainless steel spring AISI 304.

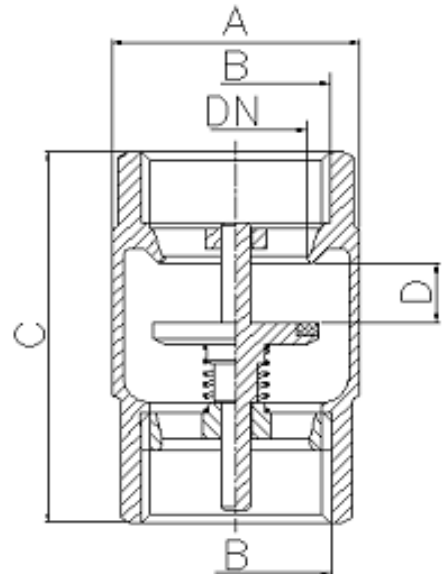
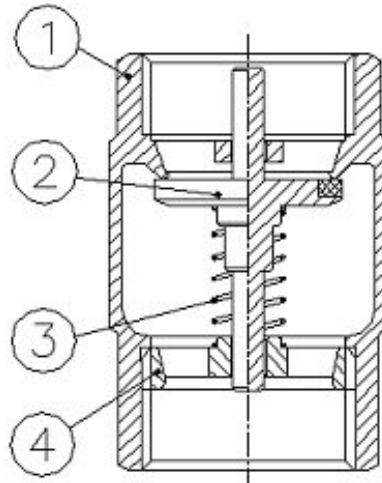

Nº	Denominación / Name	Material	Acabado Superficial / Surface Treatment
1	Cuerpo / Body	Latón / Brass CW617N	Granallado + Mecanizado / Peened + Machining
2	Clapeta / Plate	Latón + NBR / Brass + NBR	Granallado + Mecanizado + Vulcanizado / Peened + Machining + Vulcanized
3	Muelle / Spring	Acero Inox. 304 / AISI 304	-
4	Anillo / Ring	Latón / Brass CW617N	Granallado + Mecanizado / Peened + Machining

Ref.	Medida / Size B	DN	Dimensiones / Dimensions (mm)				Peso / Weight (g)
			PN	ØA	C	D	
3121 04	G 1/2"	15	25	30	50	7,5	110
3121 05	G 3/4"	20	25	36,5	57	8,5	175
3121 06	G 1"	25	25	43	65	10,5	260
3121 07	G 1 1/4"	32	18	53	70	11	375
3121 08	G 1 1/2"	40	18	64,5	75,5	12	525
3121 09	G 2"	50	18	79,5	81,5	14	800
3121 10	G 2 1/2"	65	12	104	104	22	1555
3121 11	G 3"	80	12	124	113	23,5	2335
3121 12	G 4"	100	12	155	132	27	3665

## DIAGRAMA PÉRDIDA DE CARGA / HEAD LOSS CHART (Válvula retención / Check valve)

Valores de Kv / Kv Values:

**Kv** = Es la cantidad de metros cúbicos por hora que pasará a través de la válvula generando una pérdida de carga de 1 bar.

**Kv** = The flow rate of water in cubic meters per hour that will generate a pressure drop of 1 bar across the valve.

Medida / Size	1/2"	3/4"	1"	1 1/4"	1 1/2"	2"	2 1/2"	3"	4"
Kv	4.74	8.7	13.61	21.38	31.63	46.7	78.77	111.5	176.9

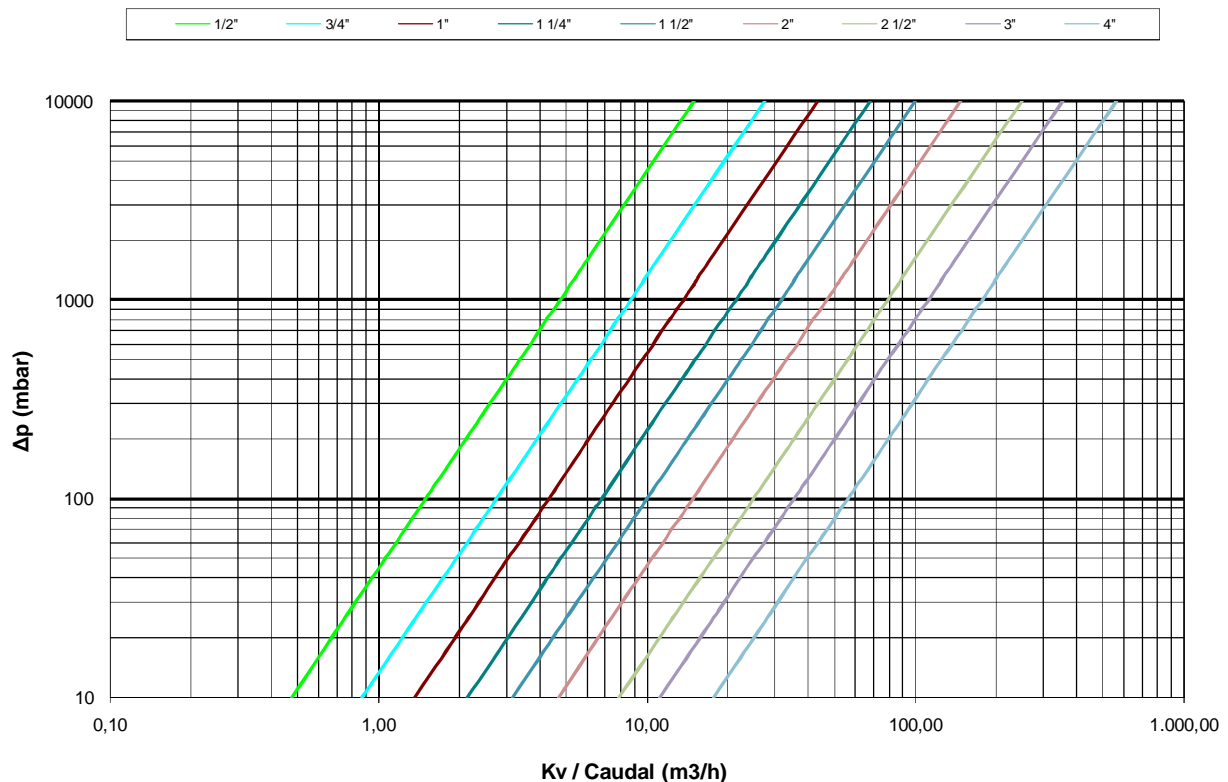

## CURVA PRESIÓN - TEMPERATURA / PRESSURE - TEMPERATURE RATING

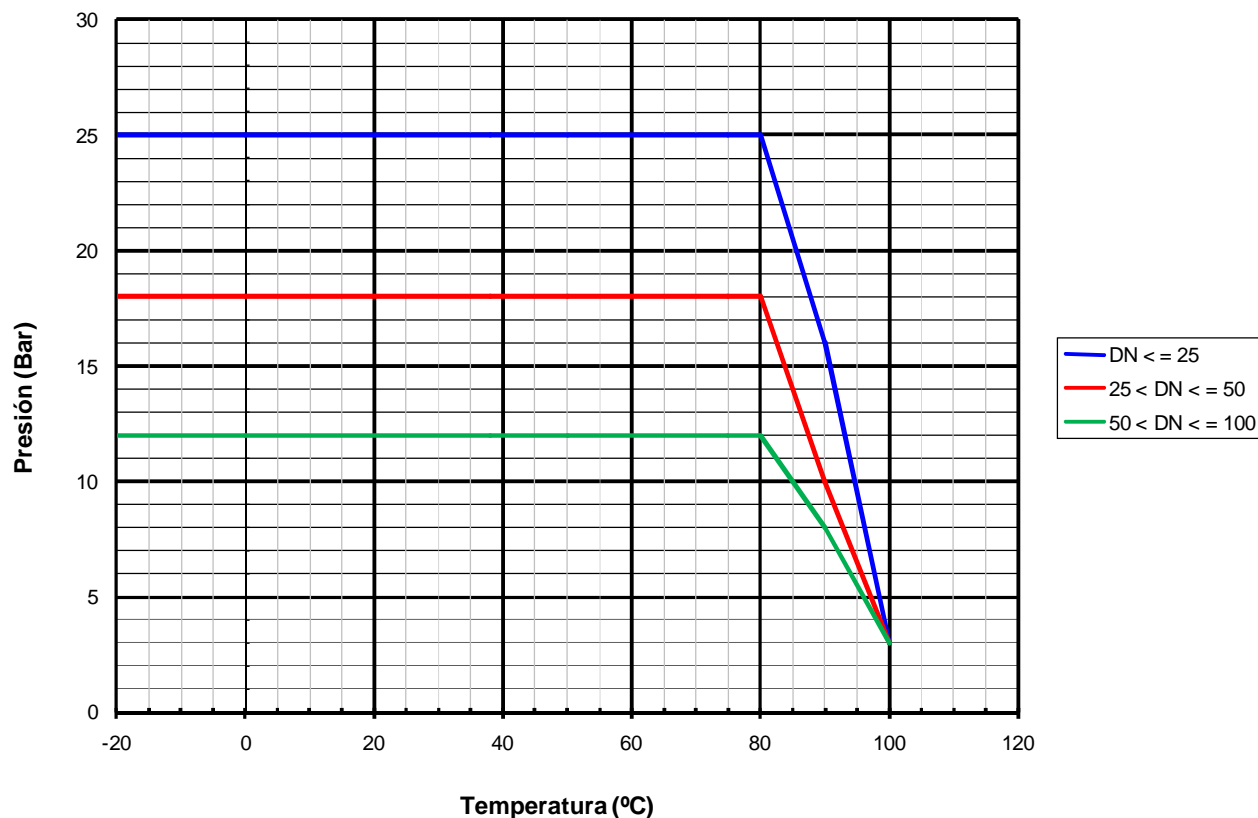

### PRESIÓN MÍNIMA DE APERTURA / MINIMUM OPENING PRESSURE

(Válvula de retención roscada 3121 / Threaded ends check valve 3121)

Medida / Size	1/2"	3/4"	1"	1 1/4"	1 1/2"	2"	2 1/2"	3"	4"
mbar	23	26	25	18	31	14	14	10	8